

Global Energy Trends, The Role of Renewable Energy & Implications for Renewable Energy & Sustainable Development in NTT Province

Part 1. Global Energy Trends, The Role of Renewable Energy & Implications for Indonesia
Part 2. Renewable Energy & Sustainable Development in NTT Province

University of Nusa Cendana, Kupang, Indonesia, Juni 2010

Part 1. Prof. Hugh Outhred, h.outhred@unsw.edu.au

Part 2. Dr. Maria Retnanestri, retnanestri@gmail.com

Outline

- Drivers for increasing use of renewable energy:
 - High & volatile fossil fuel prices, particularly for oil
 - Climate change emissions from fossil fuel combustion
- Renewable energy – current use & future potential
 - Solar, wind, biomass, geothermal, ocean, hydro
- Renewable energy engineering:
 - Solar, wind, biomass, geothermal, ocean, hydro

Renewable Energy Share of Global Final Energy Consumption, 2006

Nuclear 3 %

Fossil fuels 79 %

Renewables 18 %

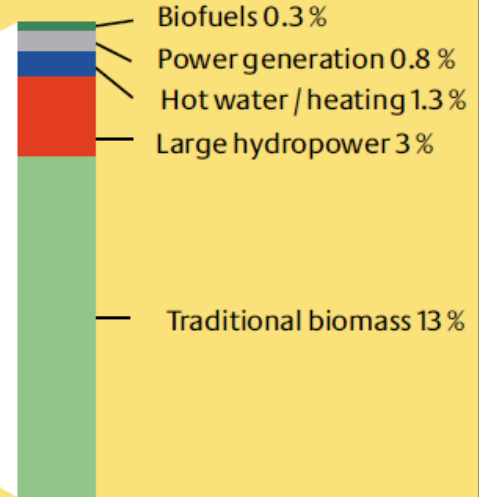
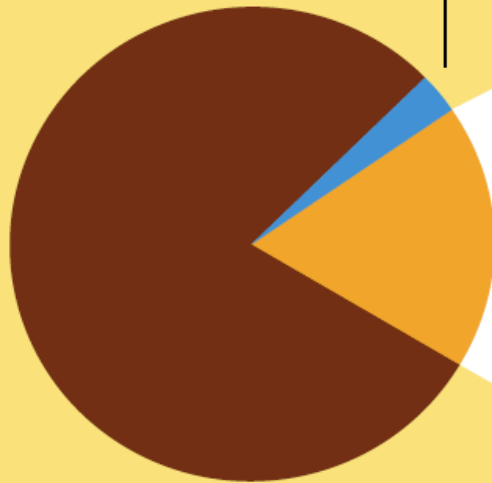

The physical potential of renewable energies

“Founding an International Renewable Energy Agency”,
IRENA, 2009

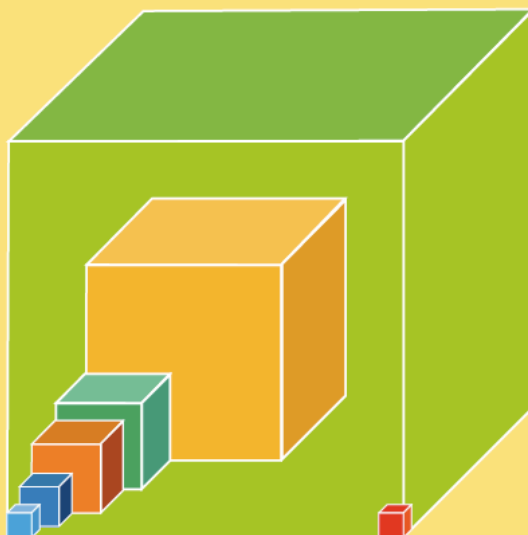

- Current global primary energy consumption (GPEC)
- Solar radiation (continents) (1800 x GPEC)
- Wind energy (200 x GPEC)
- Biomass (20 x GPEC)
- Geothermal energy (10 x GPEC)
- Ocean and wave energy (2 x GPEC)
- Hydro energy (1 x GPEC)

Note: solar & wind energy are variable & non-storable energy fluxes

Source: Nitsch, F. (2007): Technologische und energiewirtschaftliche Perspektiven erneuerbarer Energien. Deutsches Zentrum für Luft- und Raumfahrt.

Solar radiation on a perpendicular plane at the earth's surface: Southern hemisphere summer (top) & winter (bottom) (ipcc)

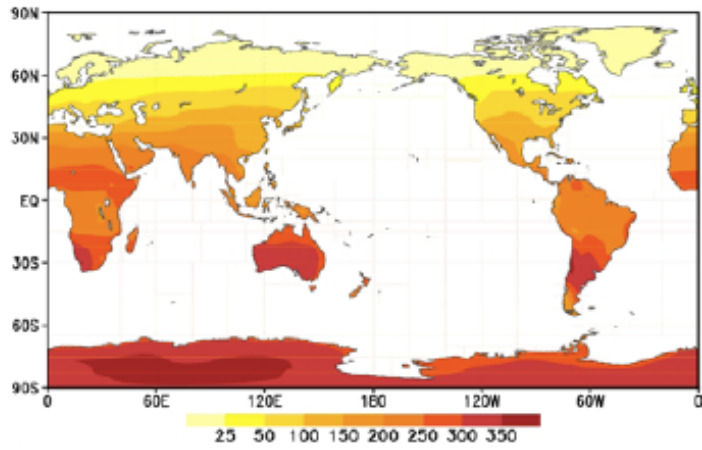

(b)

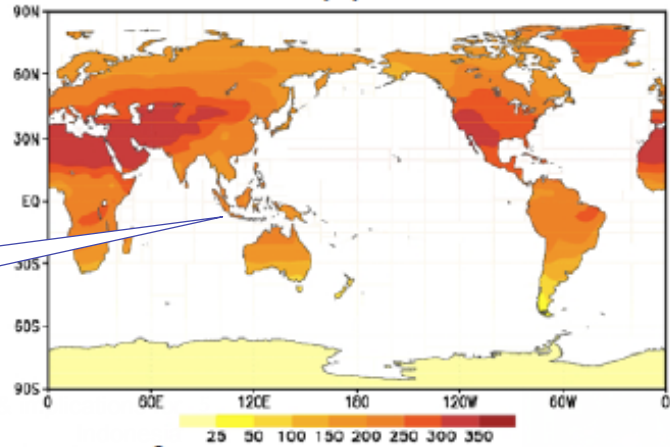

Indonesian solar energy resource ~ 17.5 MJ/m²/day ave

Global energy trends, renewable energy

Solar PV production, MW/yr (based on IEA data)

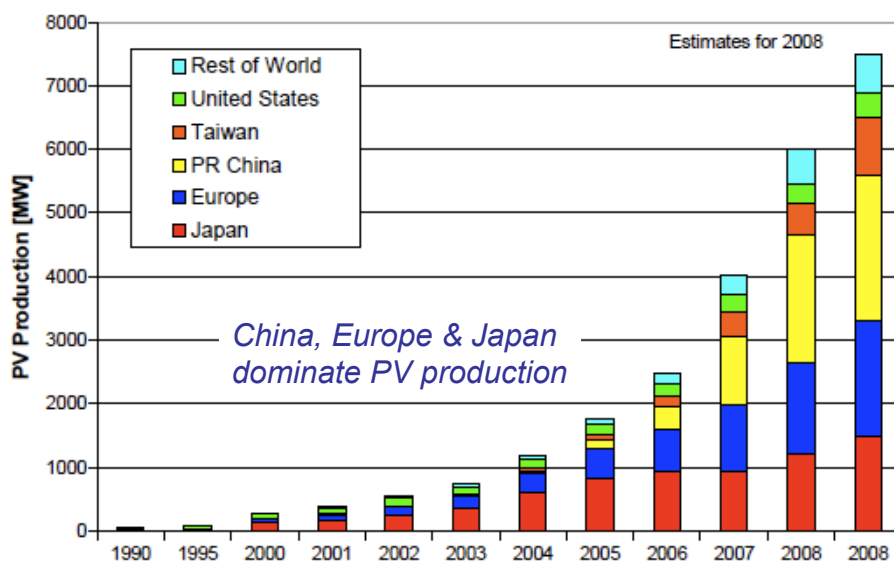

PV cost reduced by increasing manufacturing scale (MW/yr) (First Solar, 2009)

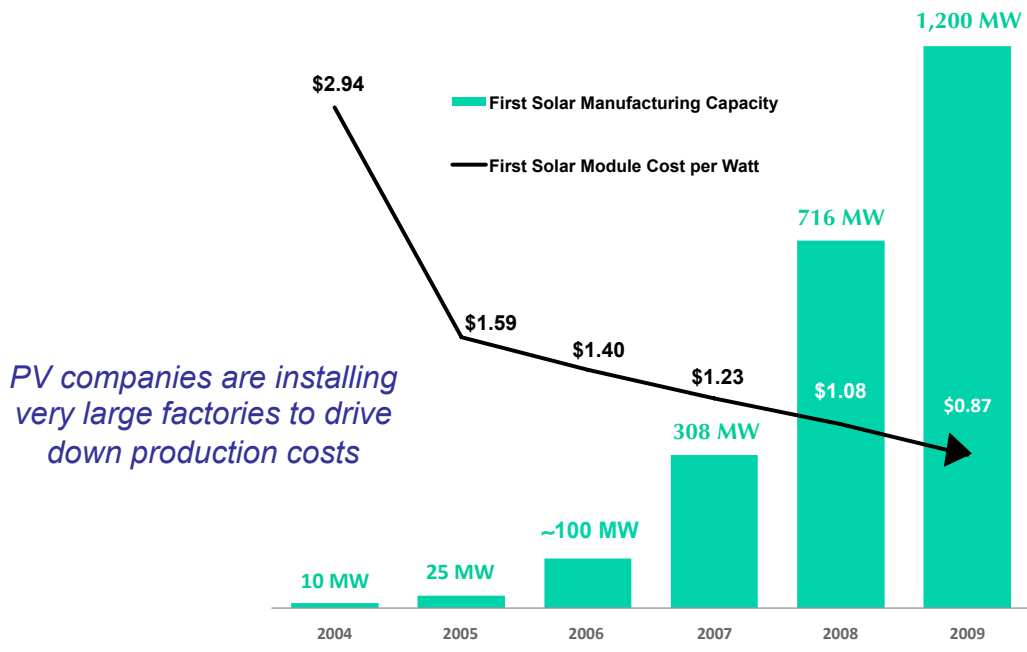

PV companies are installing very large factories to drive down production costs



Planned global PV production capacity (based on IEA data)

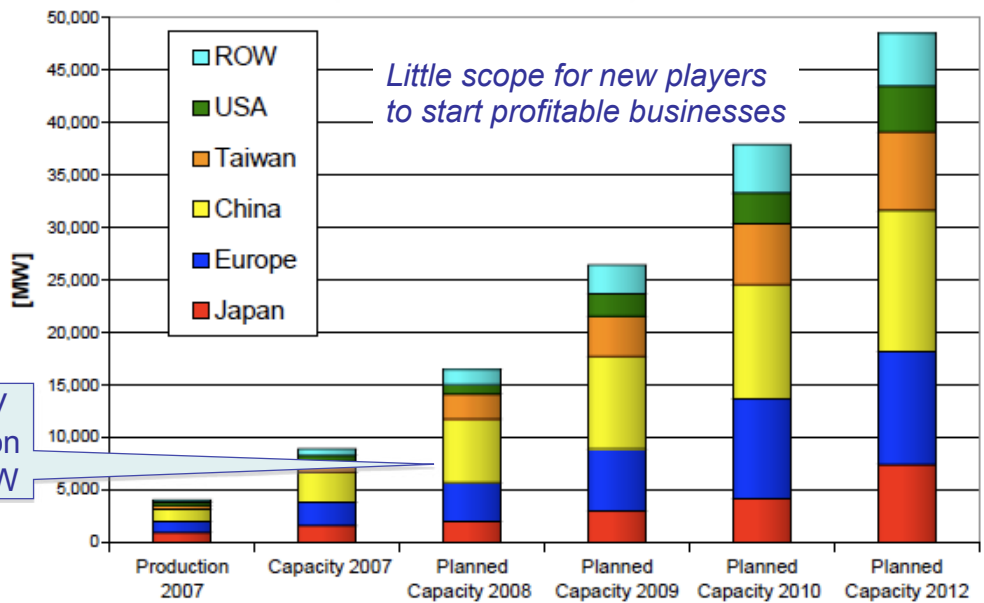

2008 PV production 7,500 MW

Little scope for new players to start profitable businesses



Cumulative installed PV capacity (REN21, 2009)

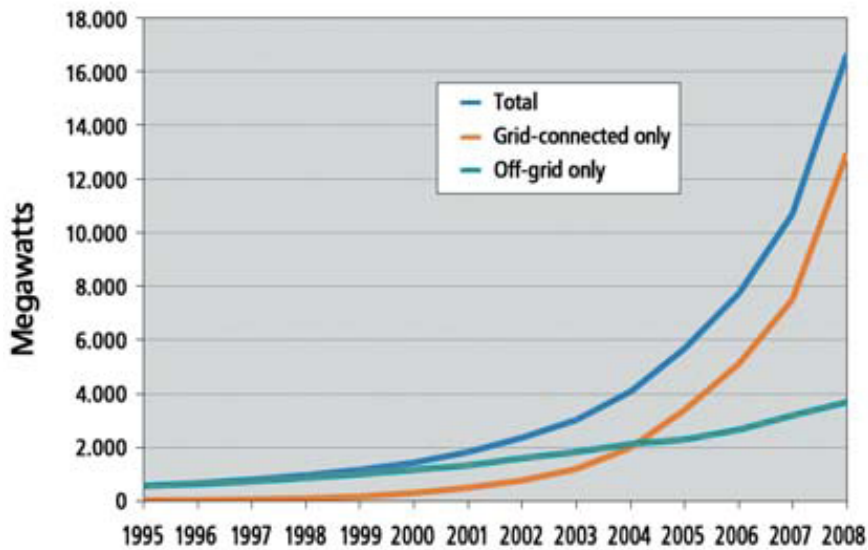

Global energy trends, renewable energy & implications for Indonesia



A range of energy-efficient lighting solutions for poor countries (Philips, 2009)

Homes, communities, shops

Orientation

Education



Uday Solar lanterns
(Cfl)
Status:
-Uday available (Ghana)
-Uday mini: com. release Q4 2009 (India-Africa)

Solar portable lantern
(Led + cfl)
Status: commercial release in Q4 2009 (Africa)

Solar Lighting System
(led, multi light)
Status: in development -release in Q1 2010 (Africa)

Led crank torch
(led+dynamo)
Status: commercially available (Africa, India)

Solar Reading Light
(led)
Status: in pilot and development

Global energy trends, renewable energy & implications for Indonesia



Some possible grid-connected PV applications

(T Key, IEEE Power & Energy Magazine, May/June 2009, p 34)

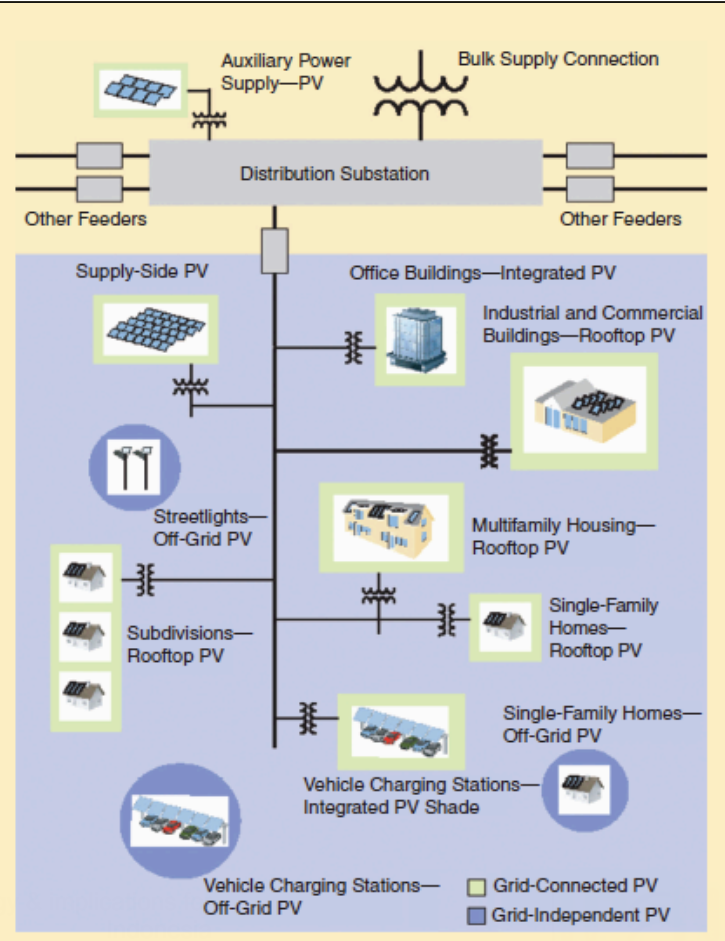

Global energy trends, renewable energy

Variability of PV production due to cloud cover

(T Key, IEEE Power & Energy Magazine, May/June 2009, p 34)

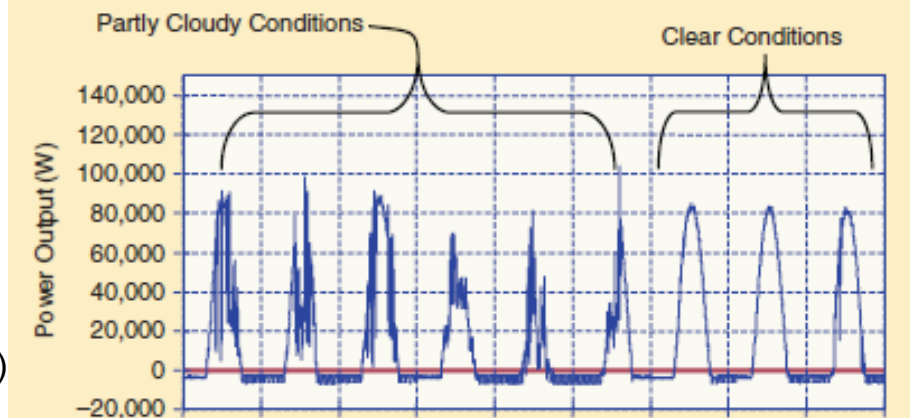

(Bebic et al, IEEE Power & Energy Magazine, May/June 2009, p 45)

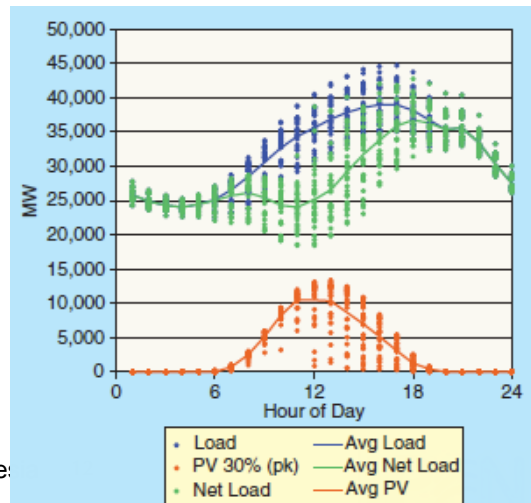

Global energy trends, renewable energy & implications for Indonesia

Concentrating solar thermal electricity generation (installed capacity & projections (IPCC))

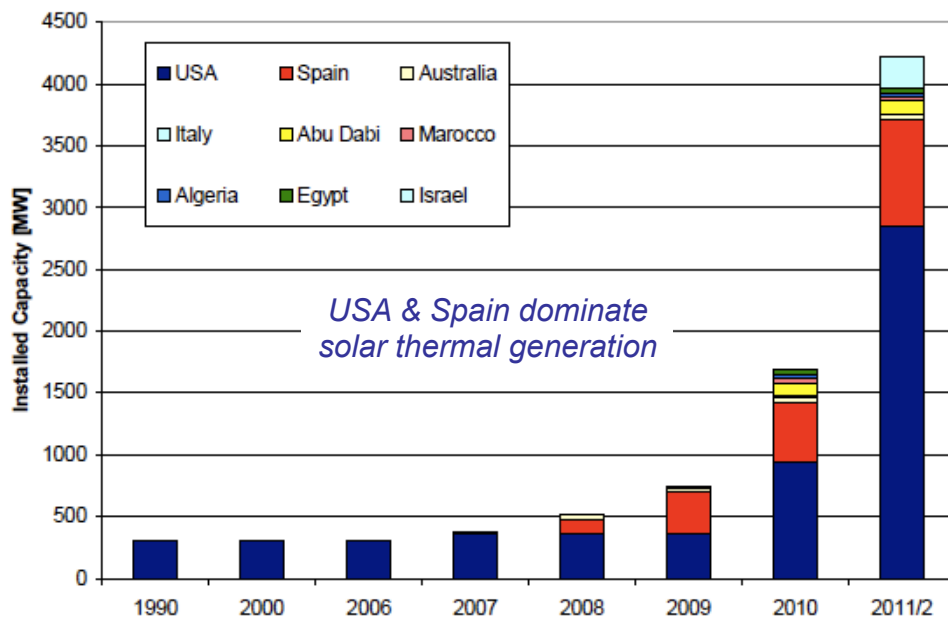

Global energy trends, renewable energy & implications for Indonesia



Solar thermal concentrators for electricity generation (www.greenpeace.org)

- Parabolic trough (~350MWe):
 - Most mature but low efficiency
- Central receiver (~10MWe):
 - High efficiency but pre-commercial
- Parabolic dish (<1MWe):
 - High efficiency but pre-commercial
- Tower (50MWe)
 - Wind from temperature differential; pre-commercial

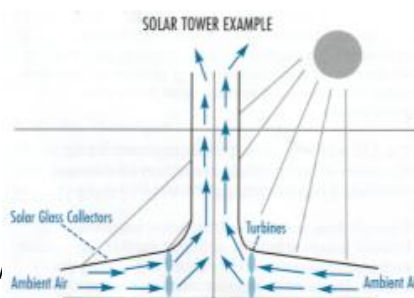
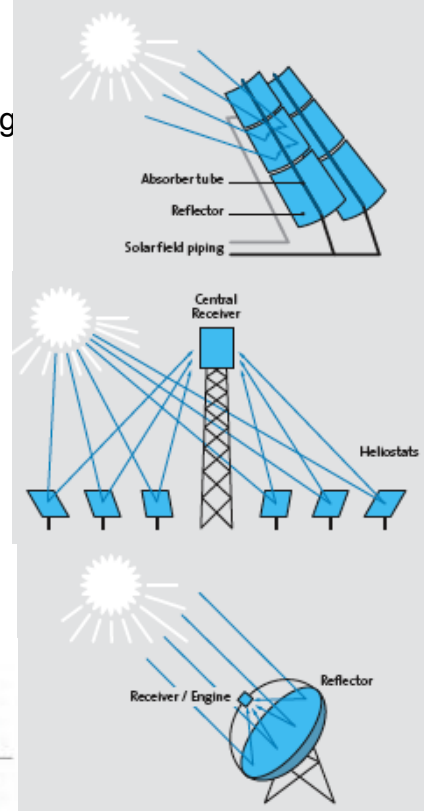

Global energy trends, renew



Fresnel solar thermal electricity generation

(www.ausra.com, 2008)



Lower efficiency than parabolic trough but may be more cost-effective

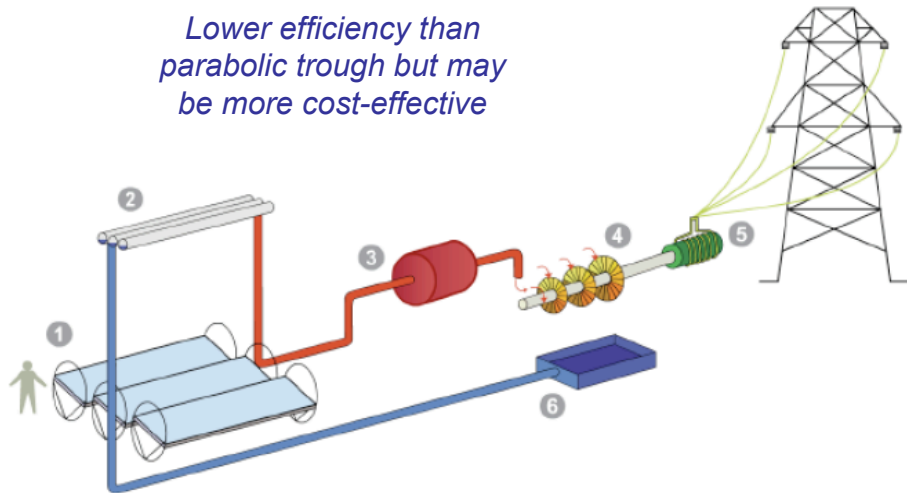

Global energy trends, renewable energy & implications for Indonesia



Wind power density

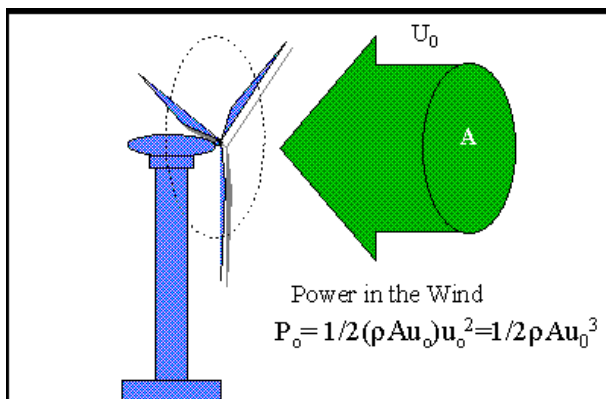

- Wind power is a non-storable energy flux
- Doubling the wind speed increases the wind power density eight times
- Doubling the turbine swept area only doubles the turbine power

(European Commission, 2005)

Global energy trends, renewable energy & implications for Indonesia



Prototype of RePower 5 MW wind turbine installed at Brunsbüttel, Germany. With a rotor diameter of 126 m, it is the largest wind turbine ever built.

A 2MW wind turbine (www.vestas.com)

Vestas V80

- Rotor Diameter: 80 m
- Speed revolution: 16.7 rpm
 - Operational: 9 - 19 rpm
- Number of blades: 3
- Tower Hub height: 60 - 67 - 78 - 100 m

- Operational data
 - Cut-in wind speed: 4 m/s
 - Nominal wind speed: 15 m/s
 - Stop wind speed: 25 m/s

- Generator Type: Asynchronous
- Gearbox Type: Planet/parallel axles

- Control Type: Microprocessor; optional remote.
Output regulation & optimisation via OptiSpeedT and OptiTip® pitch regulation.



Global energy trends, renewable energy & implications for Indonesia

Wind turbine design option: *gearbox & variable speed induction generator*

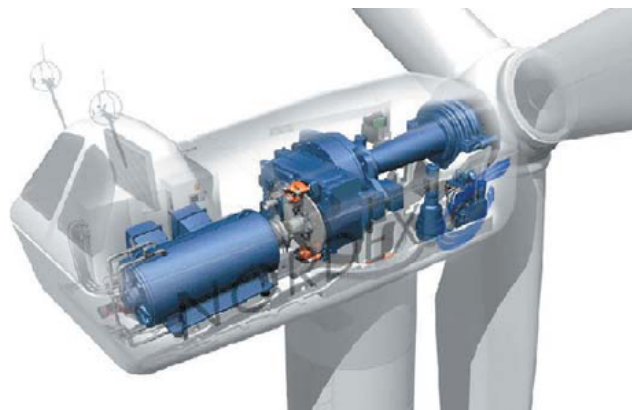

www.hydro.com.au)

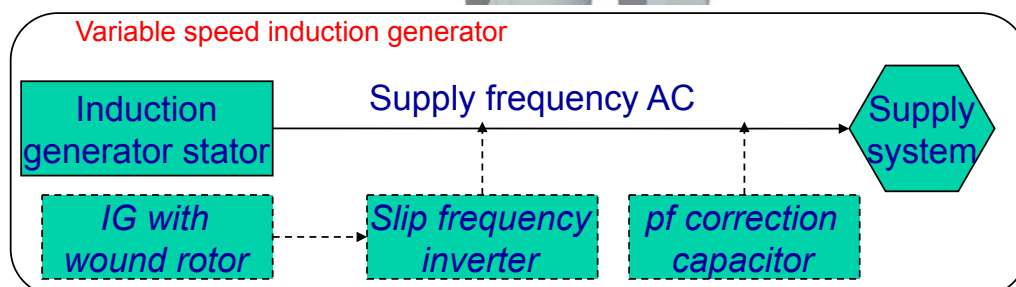

Wind turbine design option: *direct-drive variable speed alternator*



(www.enercon.de)

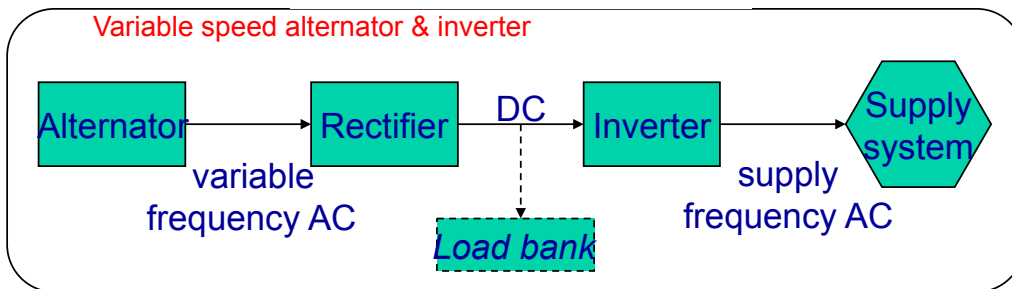

Global energy trends, renewable energy & implications for Indonesia

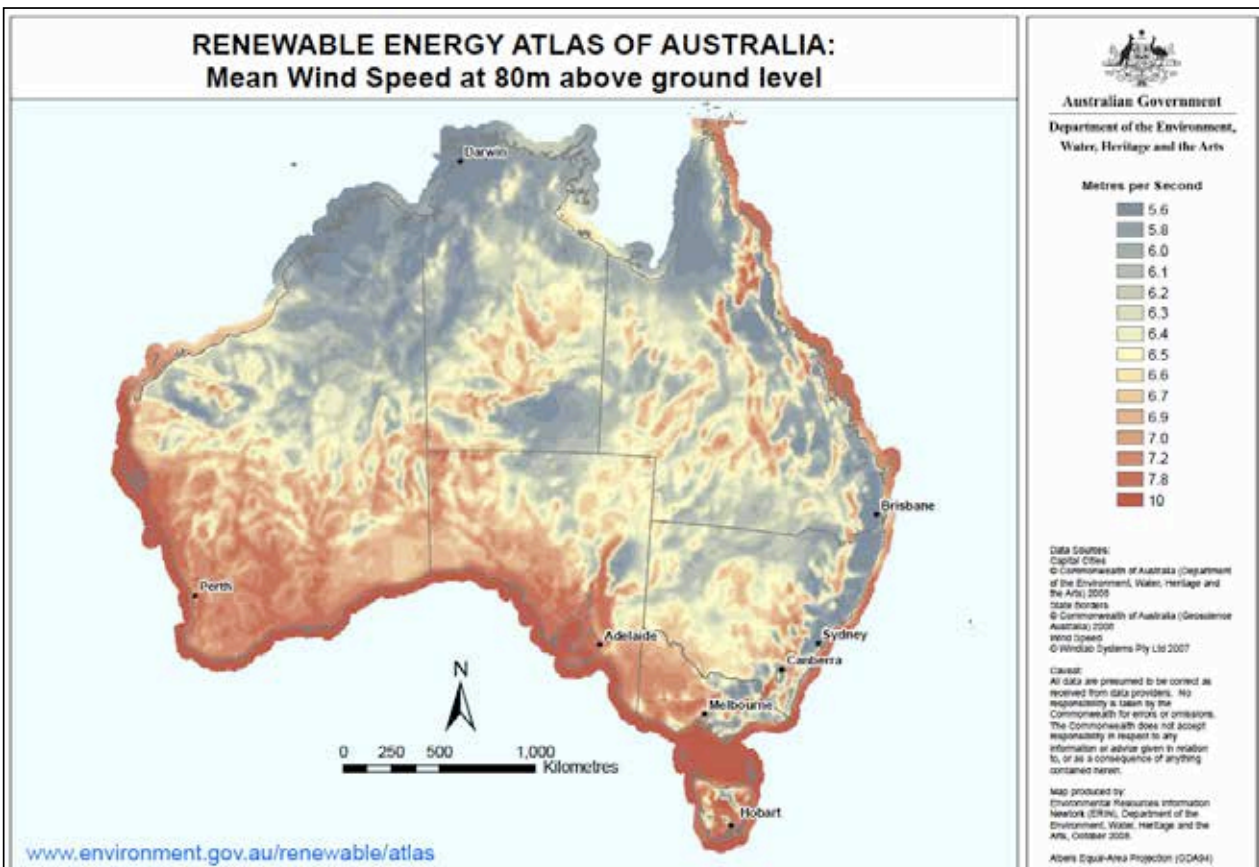

Global energy trends, renewable energy & implications for Indonesia 20



Wind generation in South Australia, Aug 08

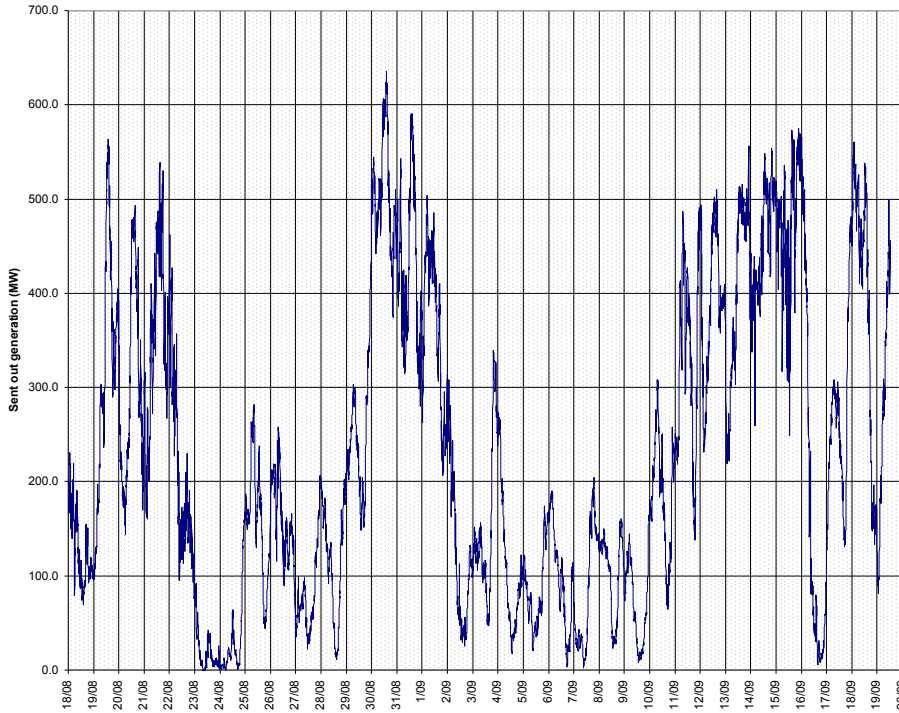

Pulau Karya in Pulau Seribu (2004)



An off-grid wind application in Indonesia

Copyright @ ripno.energin.id

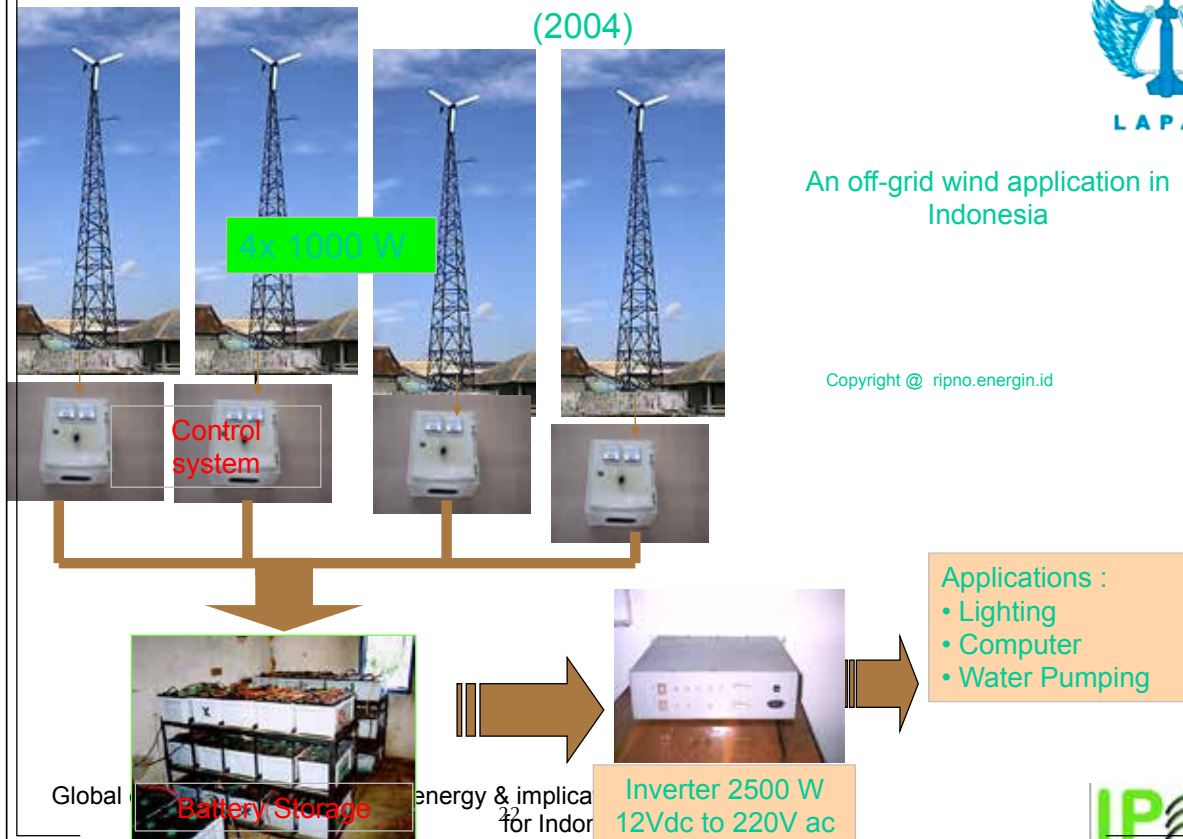

Pathways for producing energy from biomass (IPCC SRREN)

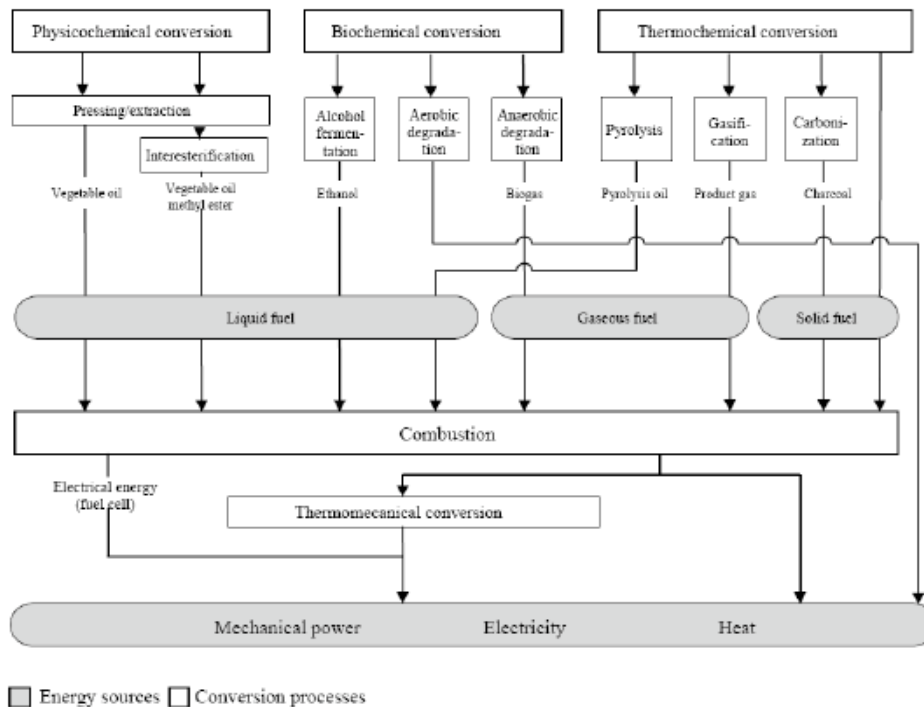

Global energy trends, renewable energy & implications for Indonesia



Projected increase in global biofuel use

- Increase 7–9% pa to meet 4–7% of global road transport fuel demand by 2030 (IEA WEO, 2006)
- Could meet 13% of global road transport fuel demand by 2050 (IEA ETP, 2006)
- Underlying concern – potential conflicts between:
 - Biofuels (ethanol & biodiesel)
 - Food production
 - Ecosystem services

Global energy trends, renewable energy & implications for Indonesia



Geothermal energy (PT Pertamina, 2009)

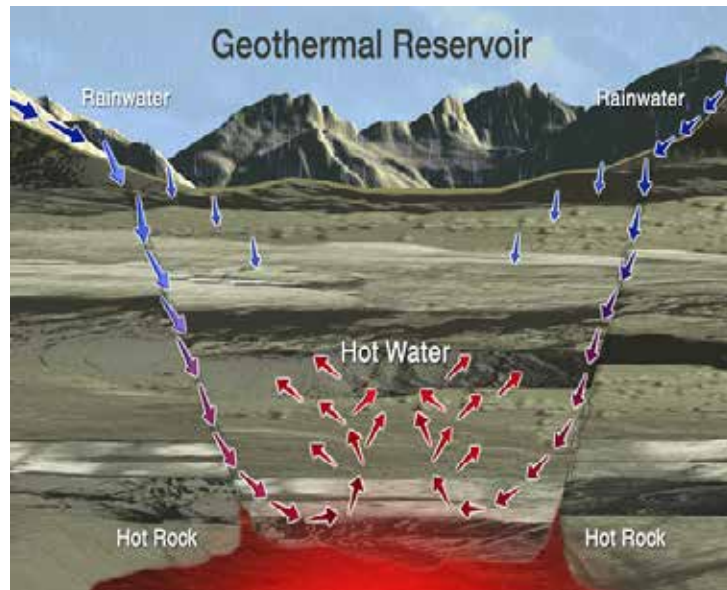

Global energy trends, renewable energy & implications for Indonesia



25

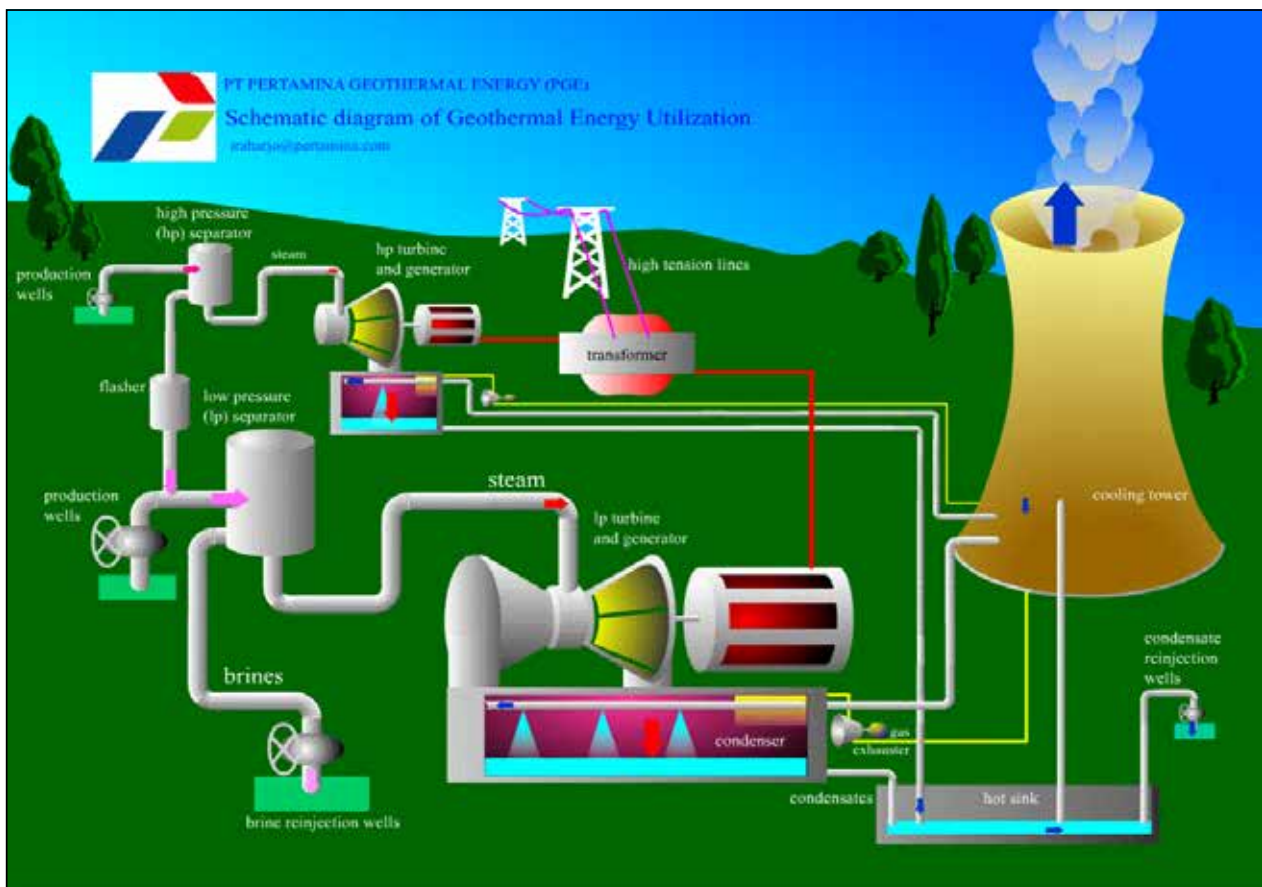

Global energy trends, renewable energy & implications for Indonesia



26

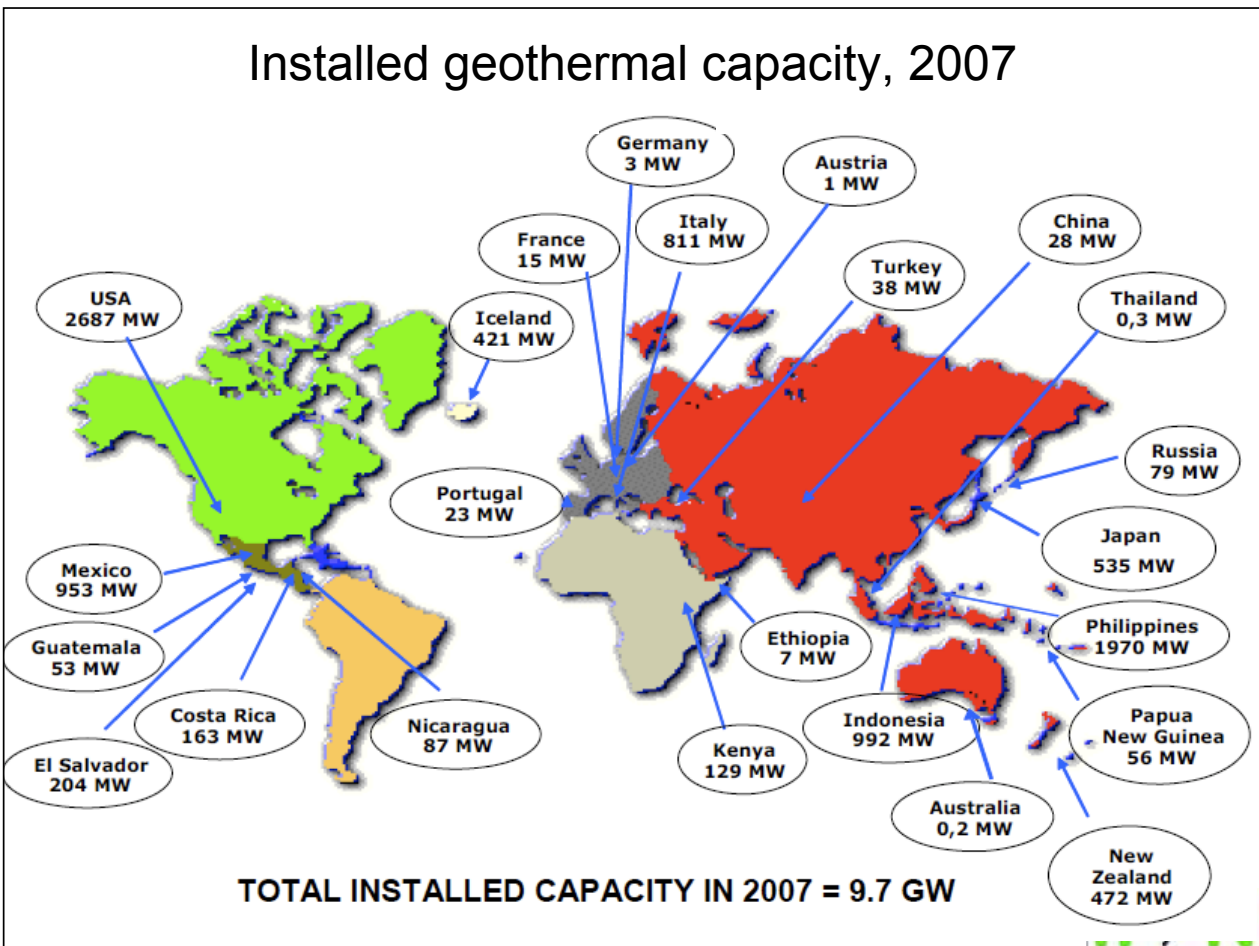
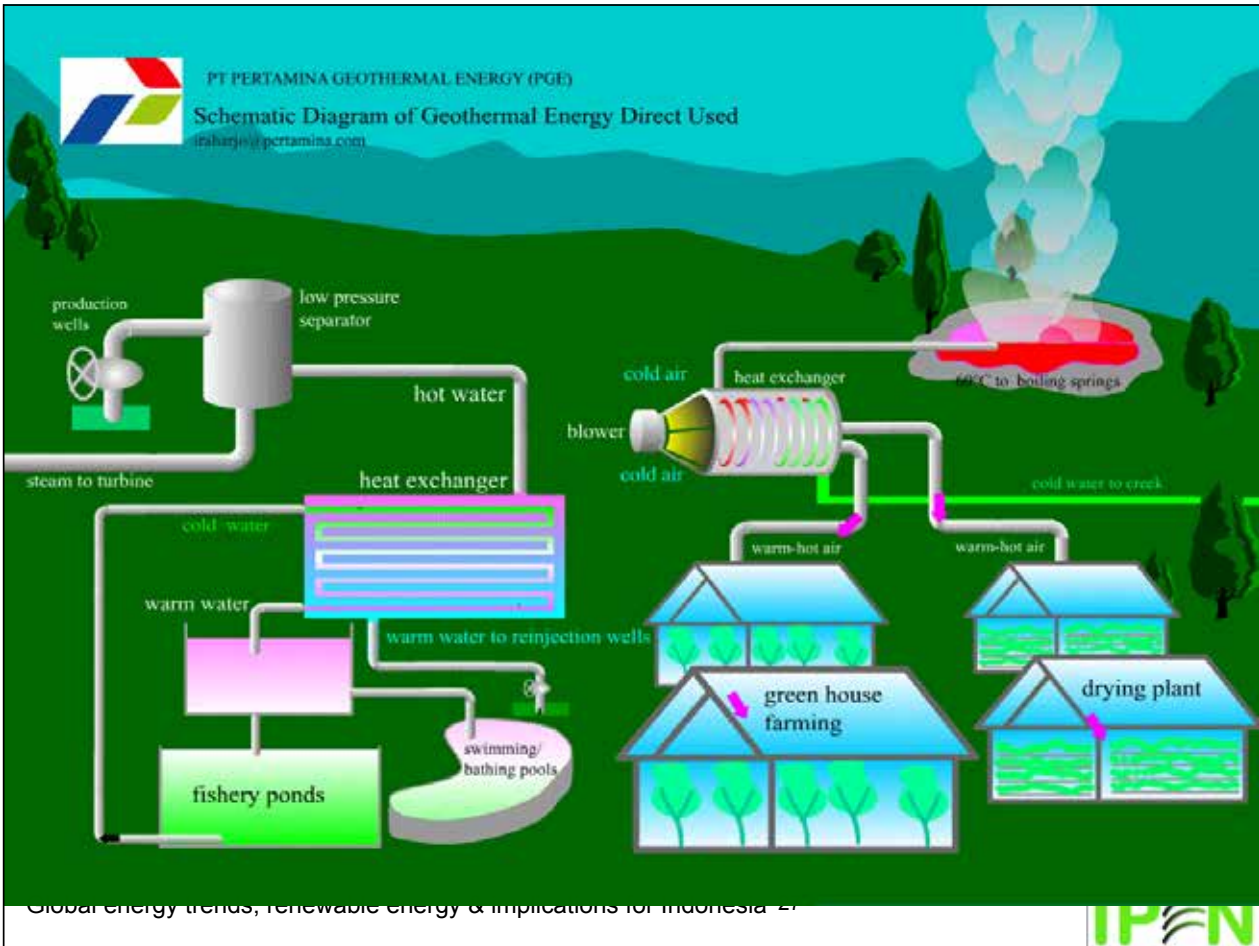

Countries with high share of geothermal electricity (2007) (GWh/yr & %)

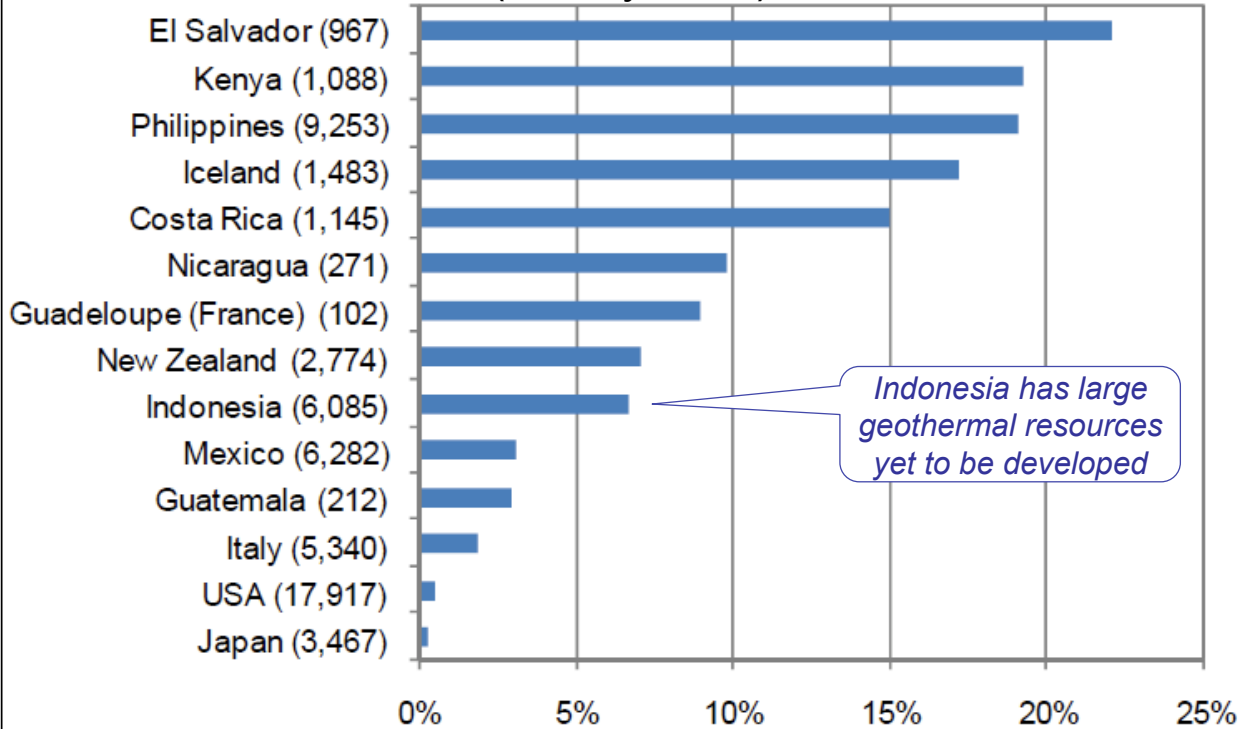

Global energy trends, renewable energy & implications for Indonesia



Hydro generation – historical use (TWh pa)

Hydro is an important option for reducing climate emissions. Installed capacity may double by 2030
Mini- & micro-hydro important in Indonesia

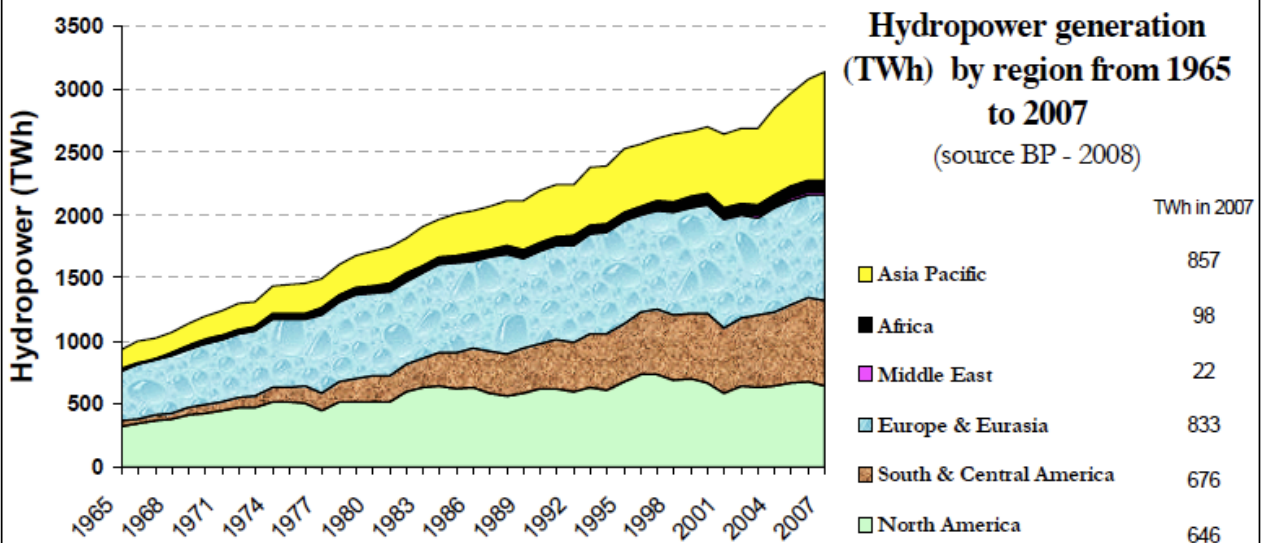

Global energy trends, renewable energy & implications for Indonesia



Indonesia has a well-established micro-hydro industry



X-flow Turbine T-14 D300
head: 3 – 100 meter
power: 10 – 150 kW



X-flow Turbine T-14 D150
head: 3 – 40 meter
power: 3 – 30 kW



X-flow Turbine T-15 D500
head: 5 – 100 meter
power: 50 – 600 kW

PROFILE *product - turbine*

**HEKSA
HYDRO**



Peltric Turbine
head: 15 – 100 meter
power: 1 – 30 kW



Propeller S-Turbine
head: 2 – 13 meter
power: 10 - 150 kW



Pelton Turbine
head: 70 – 300 meter
power: 50 – 1000 kW

Ocean energy: tidal energy

- Low-head hydro with two-directional flow
- Tidal range varies with solar-lunar alignment
- Sea water more corrosive than fresh water
- *Low head implies less cost-effective than most hydro*

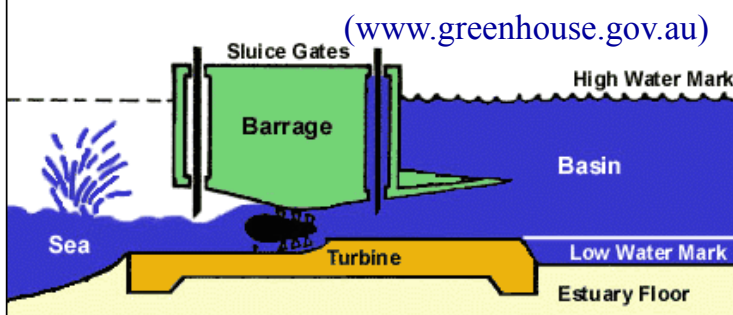

Eastern Indonesia may have good tidal energy resources

Tidal range in Australia
 (www.bom.gov.au)
 & potential tidal site near Derby, WA
 (HydroTas, 2001)

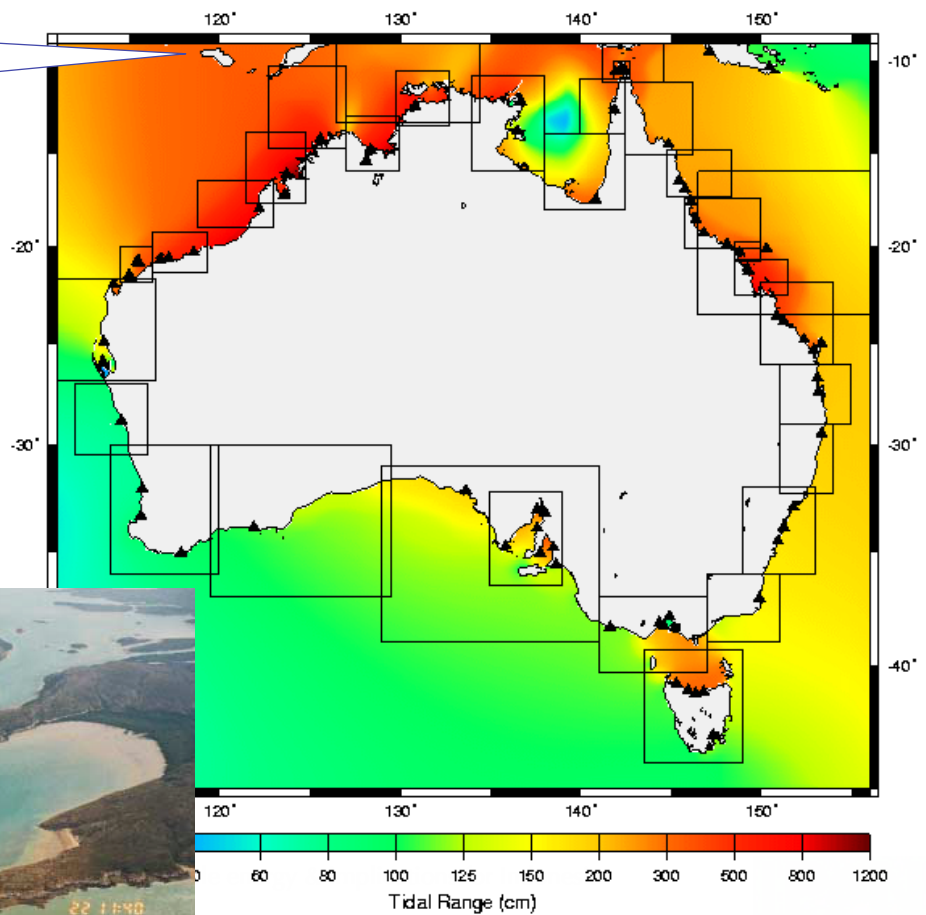

Ocean energy: Land-based wave energy conversion

- Wave energy derives from wind energy:
 - Energy density varies dramatically
- Need strength to survive storms yet cheap enough & sensitive enough to produce energy from small waves
- Land-based devices easy to build, maintain & connect to electricity grid

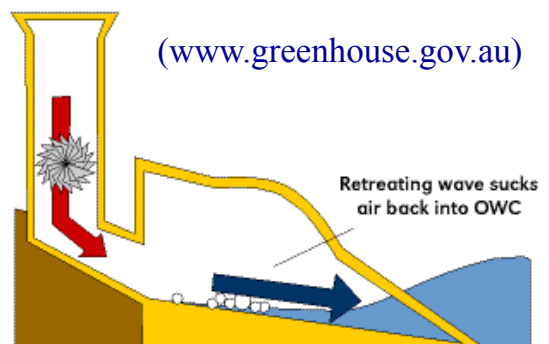
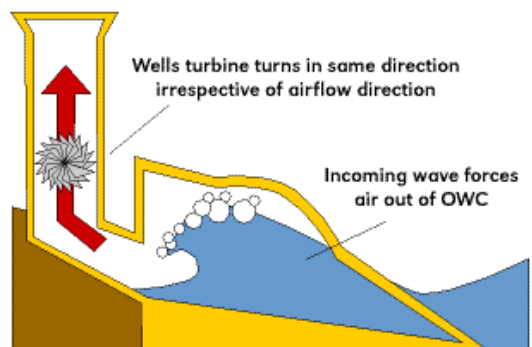

Ocean energy: Offshore waves & currents

www.oceanlinx.com

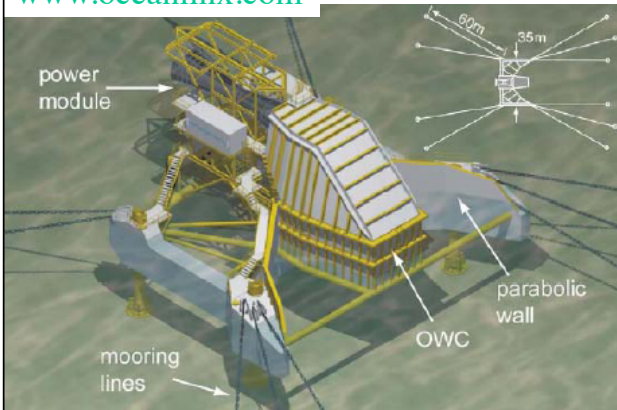

www.wavehub.co.uk

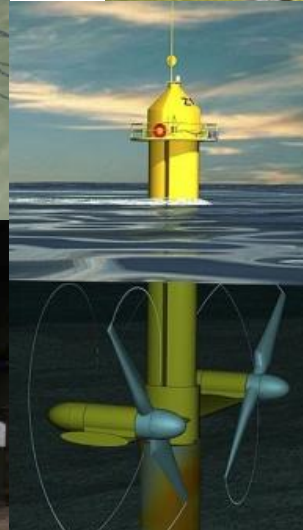

www.awsocan.com

www.marineturbines.com

RENEWABLE ENERGY ATLAS OF AUSTRALIA: Highest Wave Power

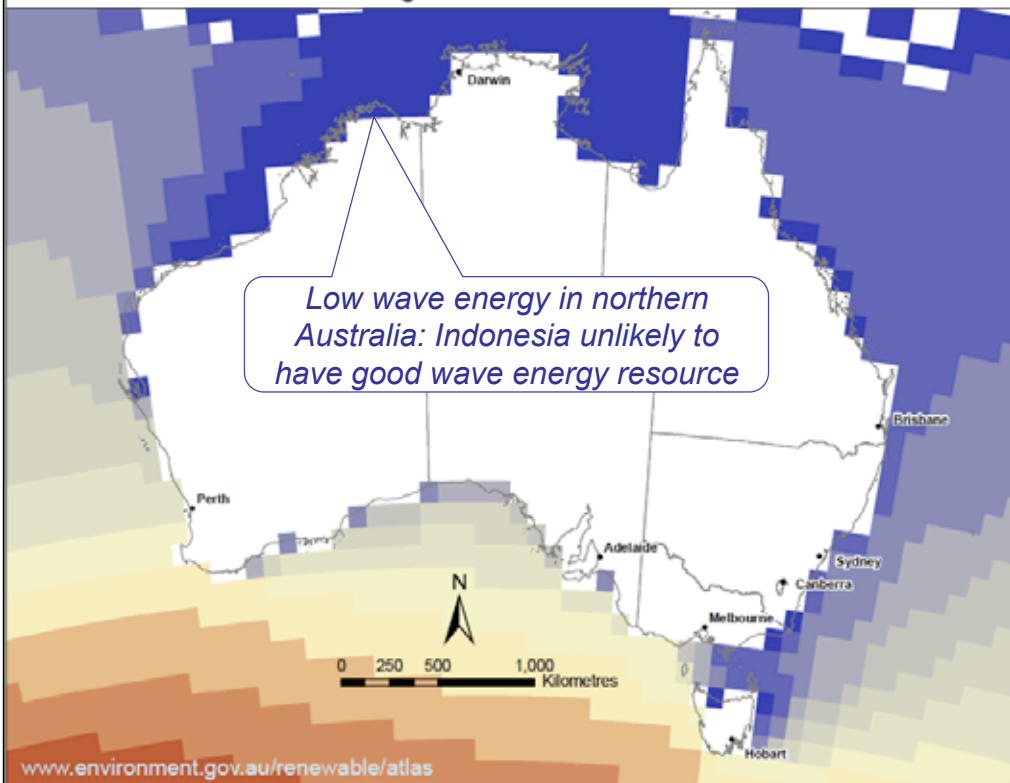

www.environment.gov.au/renewable/atlas

Australian Government
 Department of the Environment,
 Water, Heritage and the Arts

Kilowatts/m²

20
40
60
80
100
120
140
160
180
200
220
260

Data Sources:
 Capital Cities
 © Commonwealth of Australia (Department of the Environment, Water, Heritage and the Arts) 2008
 State Borders
 © Commonwealth of Australia (Geoscience Australia) 2008
 Wave Power
 © CSIRO Marine and Atmospheric Research 2008

Caution:
 All data are presumed to be correct as received from data providers. No responsibility is taken by the Commonwealth for errors or omissions. The Commonwealth does not accept responsibility in respect to any information or advice given in relation to, or as a consequence of anything contained herein.

Map produced by:
 Environmental Resources Information Network (ERIN), Department of the Environment, Water, Heritage and the Arts, October 2008.
 Albers Equal-Area Projection (GDA84)

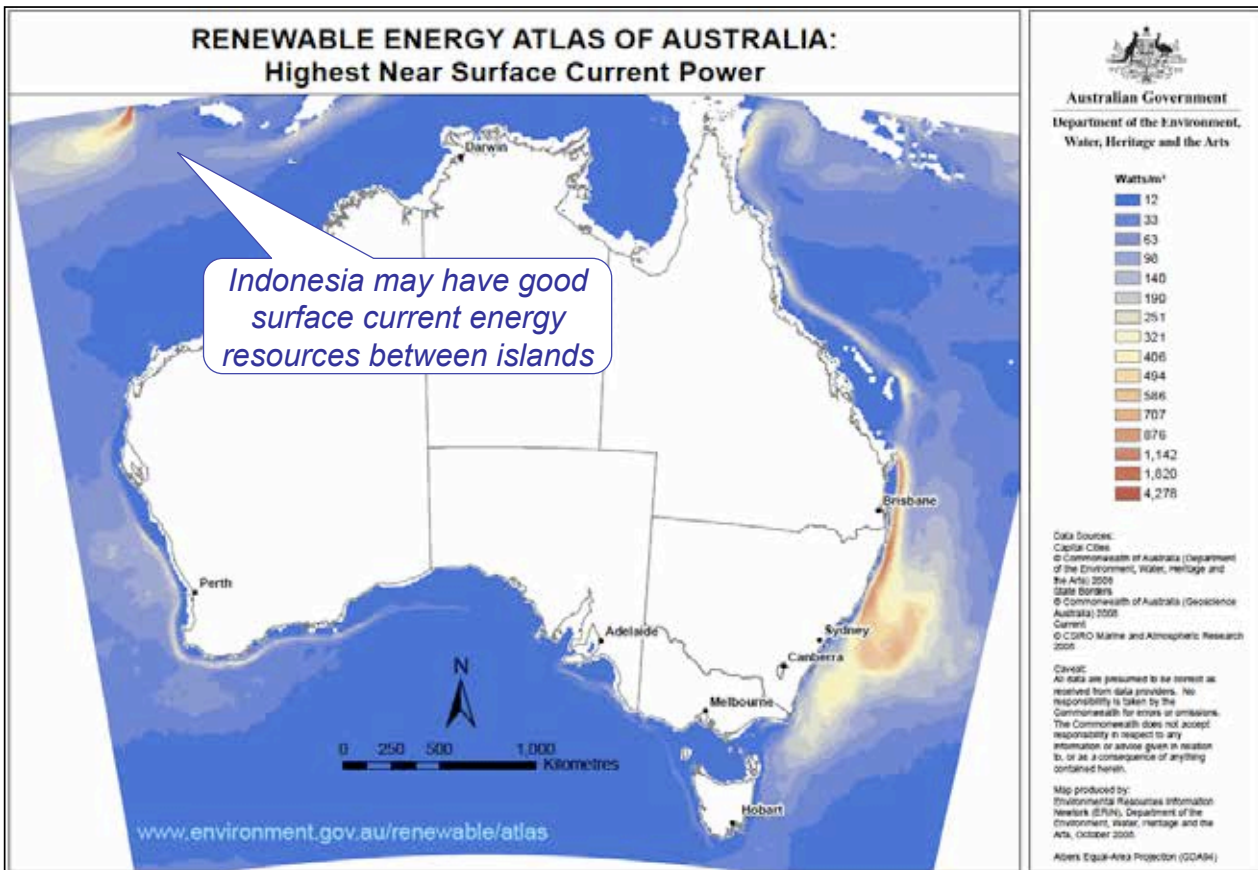

Global energy trends, renewable energy & implications for Indonesia 37



Conclusions

- Renewable energy may contribute to:
 - Responding to high fossil fuel prices
 - Reducing climate change emissions
 - Facilitating sustainable development
- To promote renewable energy in Indonesia:
 - Identify promising regional resources & applications
 - Develop understanding of renewable energy in policy makers, engineers and the community
 - Undertake well-planned renewable energy projects
 - Develop domestic renewable energy industries & expertise



Electrification Ratio & Socioeconomic Development in Indonesia *ER, HDI & HPI Correlation*

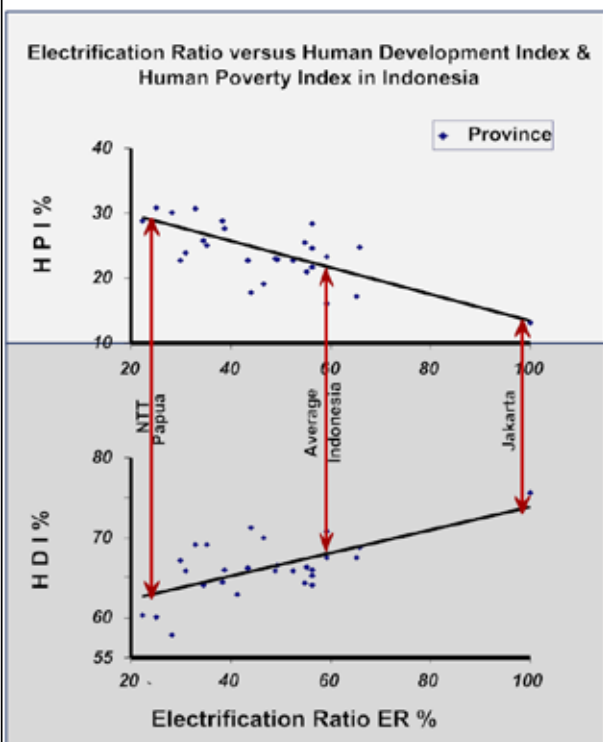

Population 238m **Electrification Ratio:** 60%,
Average kWh/capita: 564 (NTT- 74; Jak- 2077).

Current Situation: Demand growth 9%/year;
Supply growth: 3-4%/year leading to electricity
crisis; Oil share for electricity generation 63%

Future Target: 80% Electrification ratio (2014);
no more black out (2010); decreased oil usage

HDI: Life expectancy, educational attainment,
living standard

HPI: Poor health, illiteracy, poor access to clean
water and earning below a dollar a day

(PLN 2008, UNDP 2008, CIA 2008, BP PEN 2006, Sulistomo 2010)

39 PLN 2008, Indonesian Electricity Statistics 2007 ; UNDP 2008 Human Development Reports, <http://hdr.undp.org> ; CIA, 2008, The World Fact Book
Indonesia, www.cia.gov



Renewable Energy & Sustainable Development



Upper: A 120 kW Micro Hydro system in West Java (2005), a cross-flow MH turbine produced by Heksa Hydro in Bandung (2009), a Solar Home System installed on a fish farming hut at Cirata Lake (2005), PV module factory in West Java (2005),
Lower: PV entrepreneur in Lampung (2005), PV water pumping and its user in Sumba Island (2005), biogas users in Kupang (2009)



Innovation (RE) Challenges



41 **Wollongong 2008:** Wave power at Wollongong harbor
West Timor 2009: Micro Hydro installation, wind power water pumping system



Off-grid PV Applications in Indonesia (2005): Some Issues

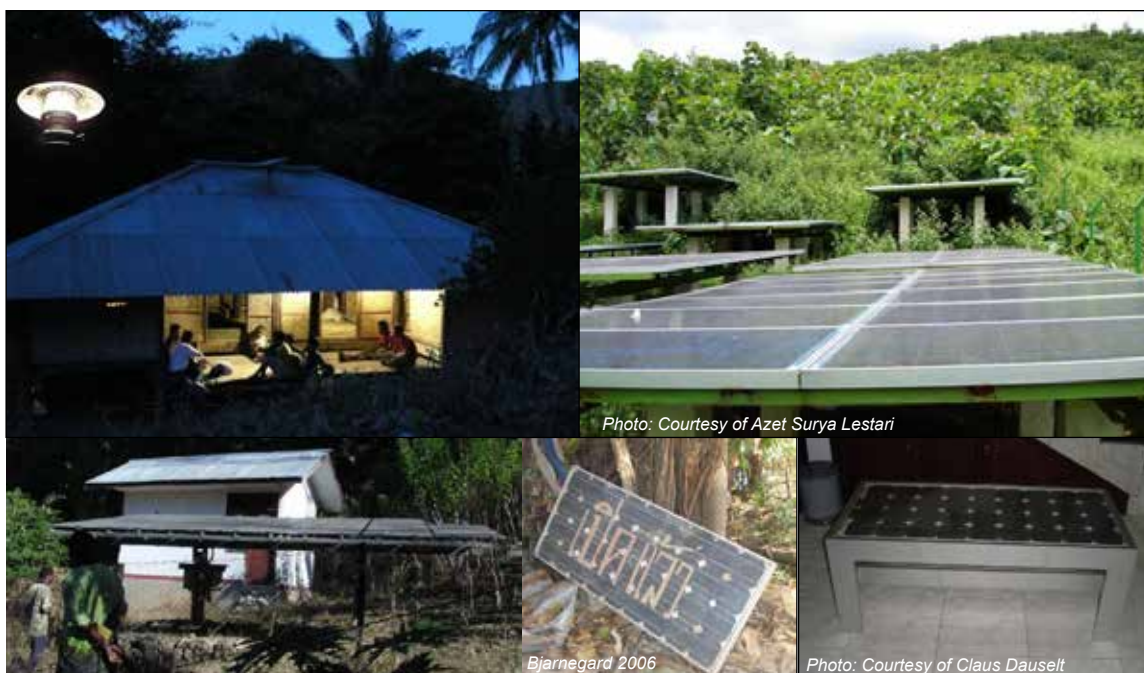

Photo: Courtesy of Azet Surya Lestari

Bjarnegard 2006

Photo: Courtesy of Claus Dauselt

Institutional: Lack of adequate after sales service infrastructure; **Financial:** Poor fund management; **Technological:** Lack of spare parts and technician availability; **Social:** Externally derived problems on rural communities leading to social fragmentation; **Ecological:** Inadequate RE waste handling, RE unsuitable in some local physical environments

RE Hardware, Software & Orgware

- **Hardware:** Equipment used in RE systems
- **Software:** Skills & information required to master the use of RE hardware
- **Orgware:** The set of institutions and rules required to develop, implement & maintain RE systems



43



I3A Framework: Electricity Services Sustainability

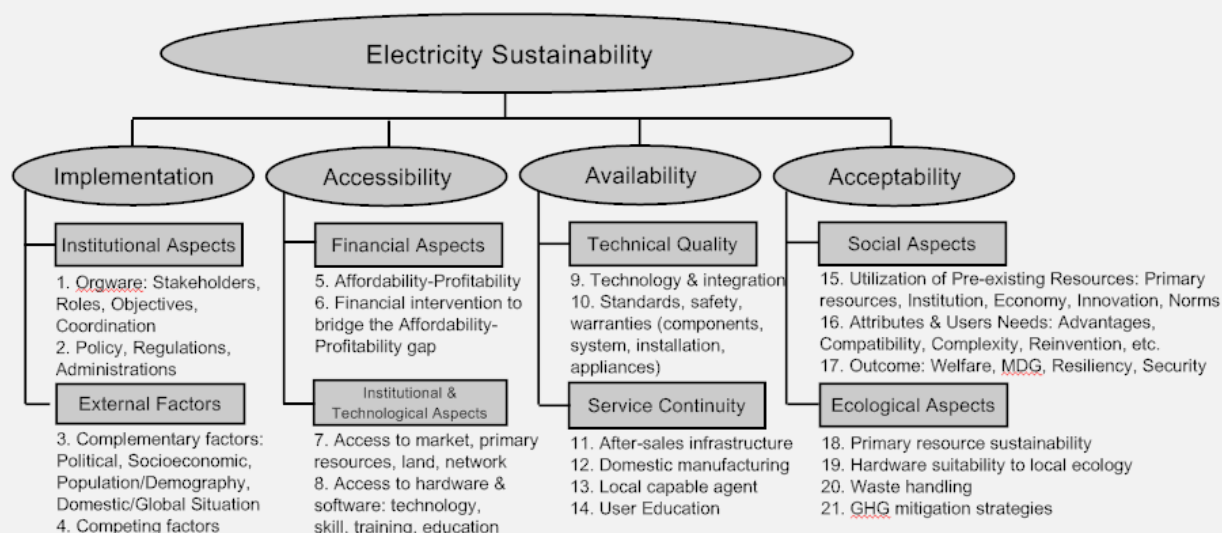

I3A Framework: An **implementation** that maintains energy service **accessibility** (financial, institutional, technological), **availability** (technological, institutional) and **acceptability** (social, ecological), considering the hardware, software and orgware aspects of energy service delivery during & beyond initial project life (Retnanestri 2007)



Implementation: Institutional Aspects – Stakeholders & Orgware

Objectives, Roles, Rules

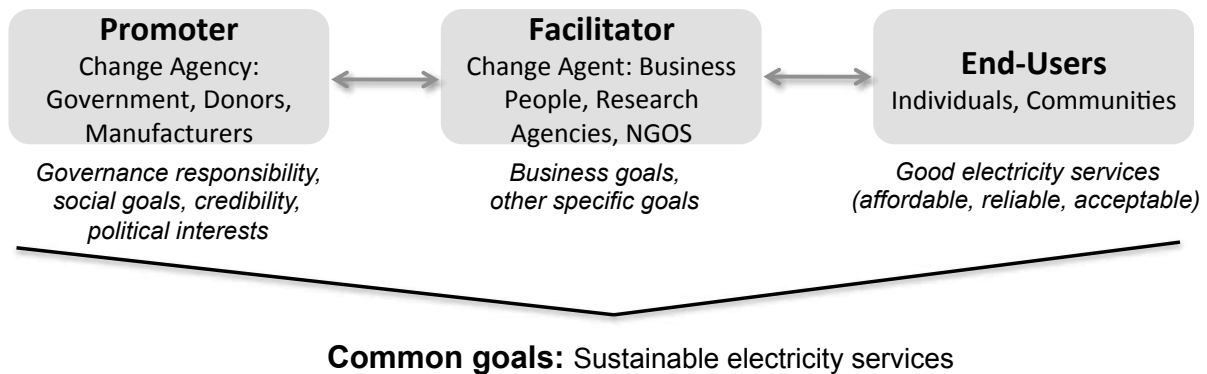

Stakeholders may have different objectives! Civic network imperative! Beware social field!

- **Civic Network** is characterized by consensus, active involvement of well-informed and capable participants, and good governance based on trust, norms and obligations among its members
- **Social field:** Battleground of differing interests

Role of facilitator as channel, linker, communicator, catalyst:

- Secure innovation adoption in the direction deemed desirable by Sponsor, balancing this with Users requirements
- Acknowledge all stakeholders interests, promote civic network, local governance, community autonomy (capacity building required)

45



Financial Accessibility & Community Empowerment

Bridging Affordability – Profitability Gap; Example Off-grid PV

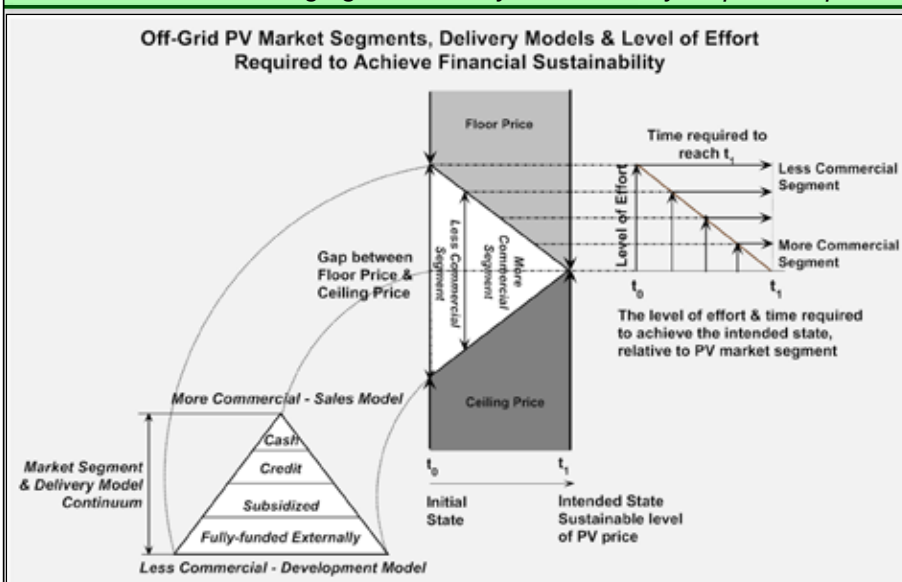

Generalization: Need relevant delivery approach for different market segment:

- **Commercial:** Market facilitation to bridge the Affordability - Profitability gap
- **Less-commercial:** Community empowerment; Empower users to be able to become part of the merchant society; Active adopters rather than passive recipients of innovation/aid

46



Technological Familiarity & the KPDAC Continuum

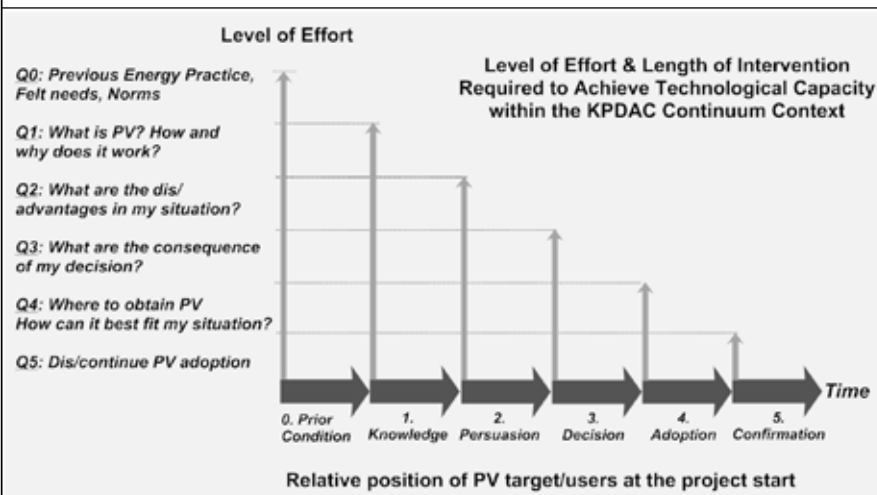

Facilitators need to understand user position in the **KPDAC continuum** at project start to facilitate RE familiarity & build user autonomy

Facilitating technological capability: The earlier the position of users in the KPDAC continuum at project start, the greater the level of effort & length of intervention required to facilitate users technological capacity in RE technology

47



Community Empowerment & Autonomy Building

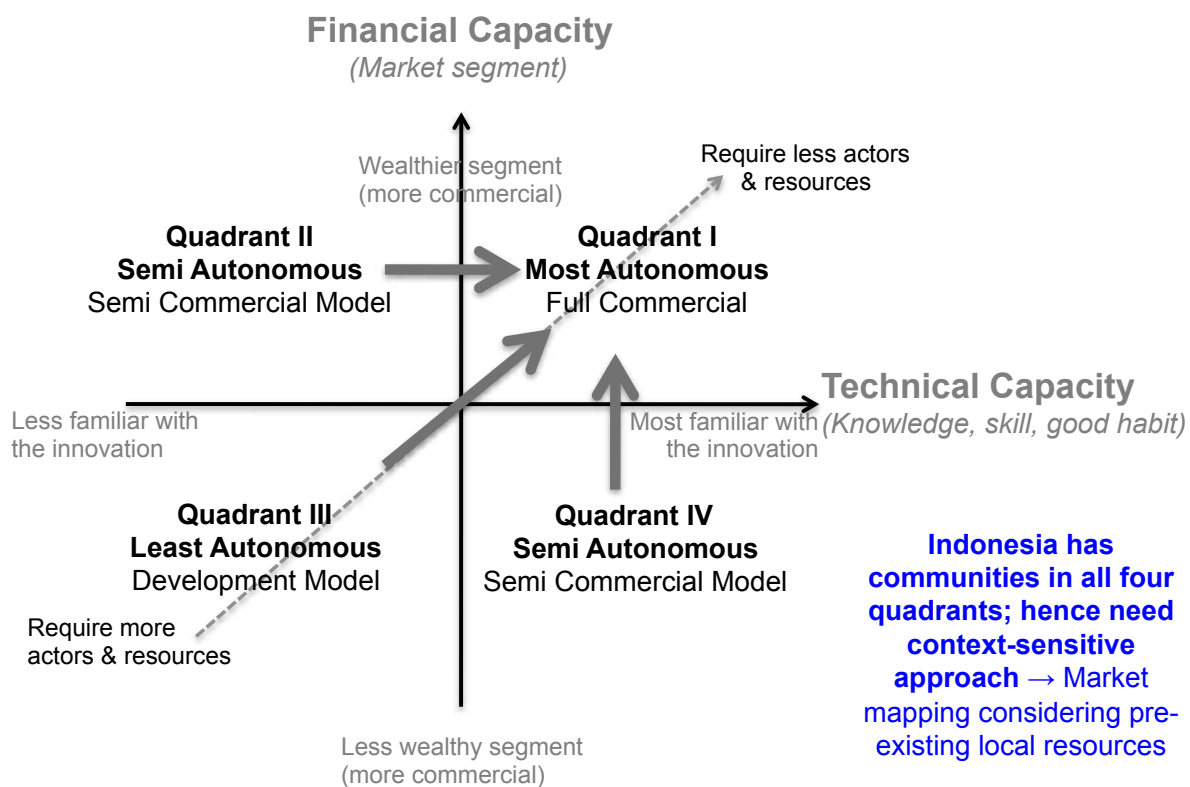

48



Availability & Acceptability: During & Beyond RE Initial Project Life Example Off-grid PV & Micro Hydro

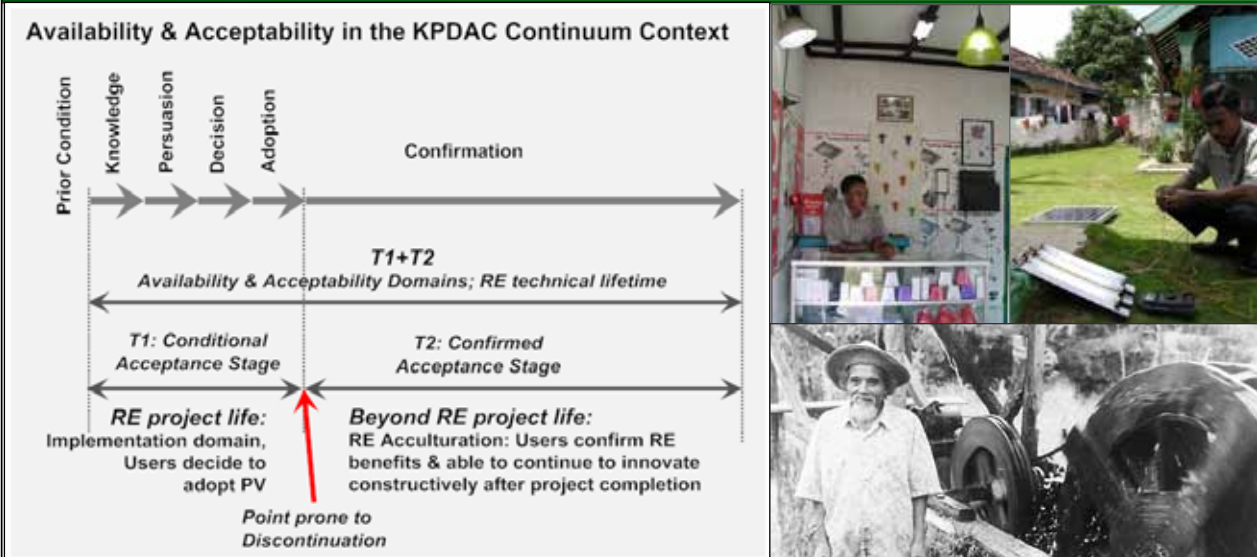

T1 & T2 Availability: Confidence in technical quality & continuity of energy service delivery (technical standards, after sales service infrastructure)

T1 & T2 Accessibility: Conditional & Confirmed Acceptance → Acculturation of energy service technology into local community's life

49



Exp: The KPDAC Continuum & Acculturation Process of RET

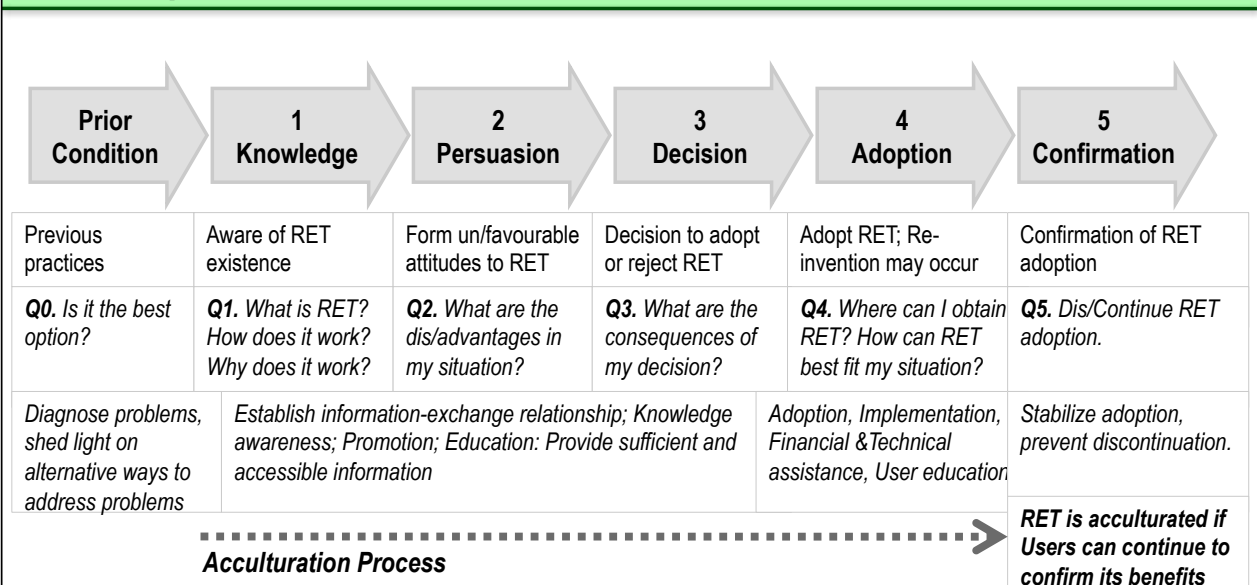

The KPDAC continuum:

- Interweaving of hardware-software-orgware that explains the what, why, who, how involved in the RET acculturation process, as well as its success or failure
- Hardware: Equipment, Software: Skill, information, Orgware: Institutional context

50



I3A Framework: Electricity Services Sustainability

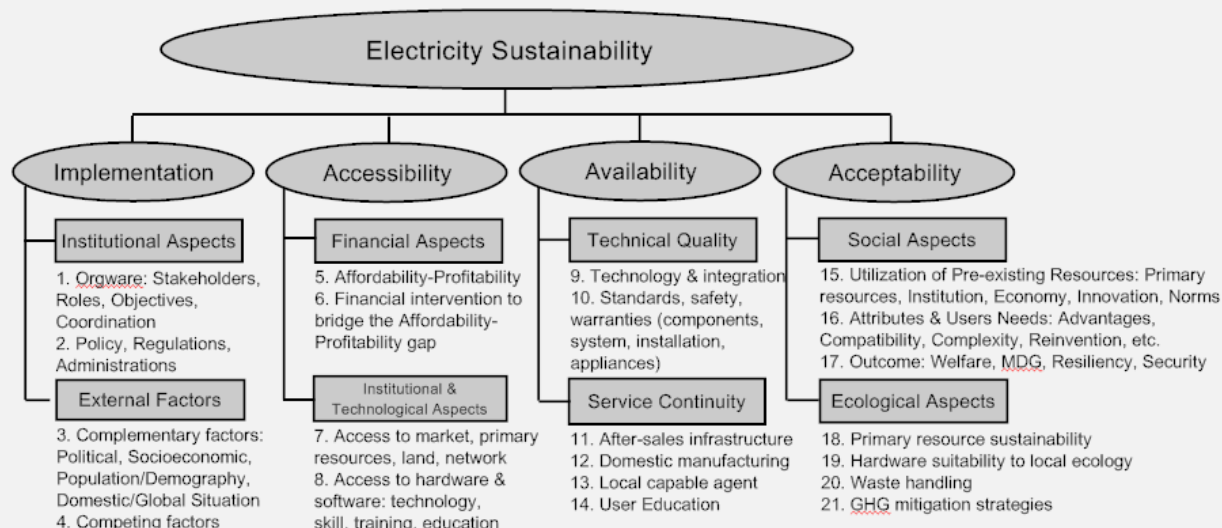

I3A Framework: An **implementation** that maintains energy service **accessibility** (financial, institutional, technological), **availability** (technological, institutional) and **acceptability** (social, ecological), considering the hardware, software and orgware aspects of energy service delivery during & beyond initial project life (*Retnanestri 2007*)

Retnanestri, 2007, The I3A Framework – Enhancing the Sustainability of Off-grid Photovoltaic Energy Service Delivery in Indonesia, PhD Thesis, <http://unsworks.unsw.edu.au/vital/access/manager/Repository/unsworks:1598>



Wrap Up

- RE may or may not contribute to sustainable development
- To be sustainable:
 - RE needs to be implemented in a way that maintains RE service accessibility, availability & acceptability
 - Consider the hardware, software & orgware aspects of RE
 - Consider the prior, during & beyond RE project periods
- Universities can play important role as RE facilitator, capacity building is required
- The I3A Framework can be used both as an assessment tool & design tool for a sustainable renewable RE service by applying the following criteria

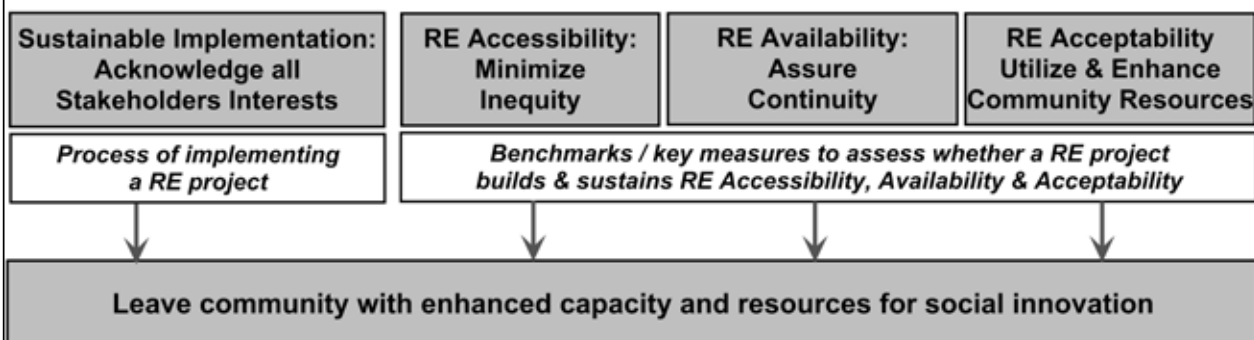

I3A Workshop 8-9 June, Kupang: Enhancing RE Sustainability in 21 Steps



UNSW-ADRA Activities: Effort to Facilitate RE Sustainability
Stakeholders engagement, networking, capacity building, sharing &



Jakarta, January: RE & Sustainable Development in Indonesia: Past Experience – Future Challenges; Jogjakarta & West Java, April - July: Study Tour & Seminar to report the study tour outcome; Kupang, West Timor: Field visit to RE sites, Seminar at UNDANA